

# BURGMAN 400 ABS



Metallic Mat Black No.2 (YKV)



Pearl Glacier White (YWW)



Metallic Mat Fibroin Gray (PGZ)

## SPECIFICATIONS

Overall Length	2,240 mm (89.2 in)	Starter system	Electric
Overall Width	760 mm (29.9 in)	Lubrication system	Wet sump
Overall Height	1,350 mm (53.1 in)	Transmission	CVT
Wheelbase	1,585 mm (62.4 in)	Suspension	Front Telescopic, coil spring, oil damped Rear Link type, coil spring, oil damped
Ground Clearance	125 mm ( 4.9 in)	Brakes	Front Disc, twin Rear Disc
Seat Height	750 mm (29.5 in)	Tires	Front 120/70-15M/C 56S, tubeless Rear 150/70-13M/C 64S, tubeless
Curb Mass	N/A	Ignition Type	Electronic ignition
Engine Type	4-stroke, 1-cylinder, liquid-cooled, DOHC	Fuel Tank Capacity	13.5L (3.6 / 3.0US / Imp gal)
Bore x Stroke	81.0 mm x 77.6 mm (3.2 in x 3.1 in)	Oil capacity (Overhaul)	1.5L (1.6 / 1.3US / Imp qt)
Displacement	399 cm <sup>3</sup> (24.4 cu. in)		
Compression Ratio	10.6 : 1		
Fuel system	Fuel injection		

## ACCESSORIES



Large Wind Screen  
Top case  
\* Maximum loading capacity is 5kg  
Heated grips  
Heated grips with pushbutton operation feature a slim new design that is almost the same thickness as standard grips and easier to grasp.  
Knuckle covers

SUZUKI MOTOR CORPORATION reserves the right to add any improvement to change the design or to discontinue any Suzuki Genuine Accessories at any time without notice. Some Suzuki Genuine Accessories might not be compatible with local standards or statutory requirements. Please check with your local AUTHORIZED SUZUKI DEALER for details at the time of ordering. Actual colours might differ from those appearing in this catalogue.

Specifications, appearances, color (including body color), equipment, materials and other aspects of the SUZUKI products shown in this catalog are subject to change by Suzuki at any time without notice and they may vary depending on local conditions or requirements. Some models are not available in some territories. Each model may be discontinued without notice. Please inquire at your local dealer for details of any such changes.

All photographs in this catalogue were taken with relevant permission.

■ Always wear a helmet, eye protection and protective clothing. ■ Enjoy riding safely.

■ Read your Owner's Manual carefully. ■ Never ride under the influence of alcohol or other drugs.

PRINTED IN JAPAN 99999-A0210-181 BURGMAN 400 ABS (AN400A) L8 Product Information

**SUZUKI MOTOR CORPORATION**

300 Takatsuka-cho, Minami-ku, Hamamatsu City, JAPAN 432-8611

[www.globalsuzuki.com](http://www.globalsuzuki.com)



Way of Life!

# BURGMAN 400 ABS



Suzuki's "Way of Life!" is the heart of our brand - every Suzuki vehicle, motorcycle and outboard motor is built to create excitement so customers can enjoy everyday life.



Way of Life!





## Svelte sophistication

Like a top athlete in peak form, the BURGMAN 400 is lean, toned and ready to perform optimally, even on narrow, twisty, or congested streets. Not only are its front and rear end slimmer, sharper and sexier than ever, this BURGMAN remains true to its family name by offering fine style that will turn as many heads out front of the office as it will in front of your favourite café or out on the road.



### Elegant and efficient LED headlight design

The slim, elegant styling of the new nose features sharply styled dual LED headlights with integrated LED position lights and turn signals mounted beneath. The overall effect creates a cleaner and lighter looking front end that is instantly recognizable as belonging to the BURGMAN family.



### LED rear combination lamps

The slim new rear of the BURGMAN 400 features independent LED rear combination lamps with the turn signals at their tips. It's a sharply sculpted design that expresses elegance and agility.



## Riding smarter

A well-informed rider is a happier and more confident rider.



### Multi-function instrumentation

Large, easy-to-read analogue speedometer and tachometer dials flank a digital display that shows an odometer, dual trip meters, fuel gauge, coolant temperature indicator, average fuel consumption meter, ambient temperature indicator, freeze indicator\*<sup>1</sup> and clock. Also included is Suzuki's Eco Drive Indicator, which come on when the vehicle is operated in a fuel-efficient manner and may help riders learn techniques to better economize on fuel\*<sup>2</sup>.

\*<sup>1</sup> The freeze indicator starts blinking when the ambient temperature falls below 3°C. It continues to blink for 30 seconds then remains lit until the ambient temperature rises above 5°C.

\*<sup>2</sup> The Eco Drive Indicator does not automatically improve fuel economy but may help riders refine their riding efficiency and improve fuel consumption. Fuel consumption may vary depending on traffic conditions, such as the frequency of starts from stop, distance driven, rate of acceleration (throttle use), chosen speed, and maintenance.

### Light, lean and lavishly appointed

The new BURGMAN 400 makes no compromises on elegant styling, even while shedding weight over its predecessor. From the sharp, lean lines of its new nose to the slim new rear end, this BURGMAN clearly personifies fine craftsmanship, technological prowess and dedication to quality.

## The Elegant Athlete

It fits well, like a fine handmade suit. It rides comfortably and performs like a champion. It manoeuvres brilliantly. And it delivers a winning combination of stylish design, practicality and convenience. The BURGMAN 400 – bringing greater class and pleasure to your journey.



\* Image sketch



# Winning Performance

## Powerful DOHC 4-valve engine

At the heart of the new BURGMAN 400's polished performance is an updated version of its powerful 399cm<sup>3</sup> four-stroke, DOHC, single-cylinder, fuel-injected engine. Changes including the new air cleaner box help produce greater low-to-midrange torque for instant response and more powerful acceleration when riding in stop-and-go traffic, while also providing more powerful performance when riding tandem. Suzuki's Automatic Idle Speed Control (ISC) continues to ensure optimal idling.

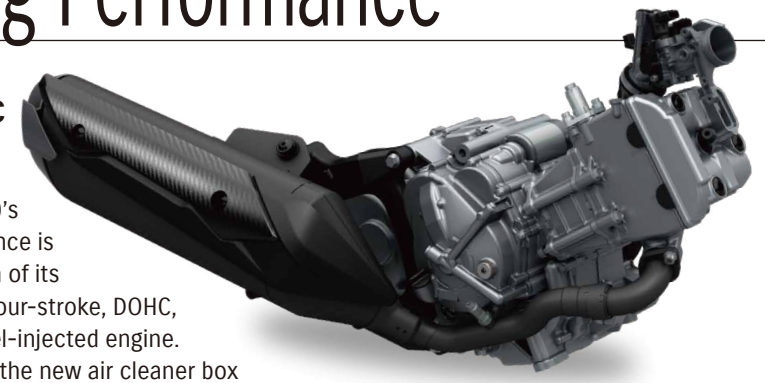

## Superior fuel economy and riding range

Despite the increase in low-to-midrange torque production, the efficiency of the new engine, including the introduction of an iridium spark plug, combines with reduction in weight to realise improved fuel economy and extends the BURGMAN 400's riding range.



## Iridium spark plug

The engine employs an iridium spark plug that contributes to higher combustion efficiency, greater power output, more linear throttle response and easier engine starts.

## Stop on a dime

The new BURGMAN 400 is equipped with a powerful braking system worthy of a sporty scooter. The front wheel carries a pair of 260mm disc brakes, while stopping power in the rear is provided by a 210mm disc brake. An Antilock Brake System (ABS)\* monitors wheel speed and matches stopping power to available traction to provide greater confidence and control. The system adopts a new compact and lightweight ABS control unit that reduces weight by approximately 750g over the previous model.



ABS unit

From the instant response and powerful acceleration of its 399cm<sup>3</sup> DOHC engine, and the exhilarating sound of the tuned intake note, to the nimble handling provided by the link-type rear suspension and new 15-inch wheel in the front, the BURGMAN 400 is built to deliver winning performance.



## Larger 15-inch front wheel

The new BURGMAN 400 replaces the 14-inch wheel of its predecessor and introduces a larger 15-inch wheel in the front. The change brings a bold new image with it and a look of stability that can instil greater confidence in the rider.

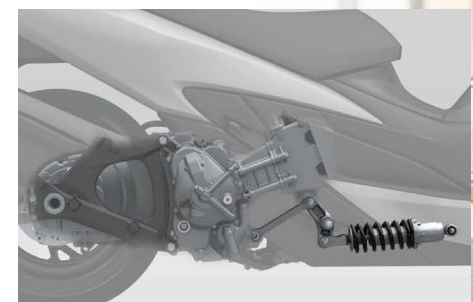

## Luxurious ride and handling

The new BURGMAN 400's underbone frame is built from large-diameter, thin-wall tubes that deliver the light weight and rigidity required for great handling. Complementing this frame in realizing a stable, relaxing and nimble ride are 41mm front forks with a generous 110mm of wheel travel. In addition, the link-type monoshock rear suspension with 7-way adjustable spring preload helps maximise the balance between comfort and sporty performance by providing a softer ride on relatively smooth roads and solid traction on cobblestone streets. Exceptional handling and manoeuvrability are the result.

## Your protective window on the world

The new BURGMAN 400's upswept windscreen creates a cleaner, more compact look from the front or sides. At the same time, it matches its predecessor in delivering optimum wind protection for rider comfort, as well as a clear view of the road.

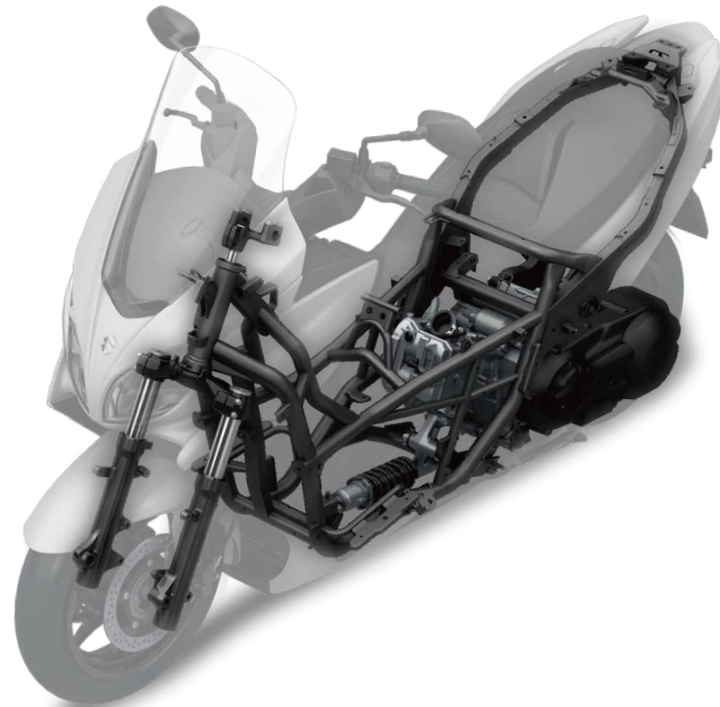





# Maximising Comfort and Utility

Maximum comfort and practicality of the highest level are important elements in achieving winning performance. With the new BURGMAN 400, all these essential elements are firmly in place.



### Sit in the lap of luxury

The stepped dual seat offers luxurious comfort for rider and passenger alike by combining a cushion that is 20mm thicker and a shape that is slimmer than on the current model. Double stitching adds a distinctively fashionable accent.



### Adjustable backrest

The rider's backrest can be adjusted 15mm or 30mm forward to provide optimal support and comfort for riders of various builds on longer outings.



### Opulent front storage

Two front compartments provide 3.5 litres\*<sup>1</sup> of storage space on the right side and 2.8 litres\*<sup>2</sup> on the left side for maps and other items.

\*<sup>1</sup> The weight limit for items in the right storage bay is 1.5kg.

\*<sup>2</sup> The weight limit for items in the left storage bay is 0.5kg.



### Bringing more power to the rider

The right storage bay has a 12V DC outlet\* for charging your mobile phone or other electronic devices.

\*To prevent draining the battery, please make sure to use the outlet only while the engine is running.



### Rich underseat storage space

The BURGMAN 400's spacious 42-litre underseat storage\*<sup>1</sup> compartment can hold two helmets\*<sup>2</sup> and provides ample room for stowing your gear.

- Helmets and luggage items are shown for illustrative purposes only.
- Do not use the storage compartments for items that are fragile, valuable, dangerous or susceptible to heat.

\*<sup>1</sup> The weight limit for items in the underseat compartment is 10kg.

\*<sup>2</sup> One full-face and one demi-jet helmet may fit in the underseat compartment. Helmets of certain shapes may not fit in the underseat compartment.



### Greater peace of mind

Security technologies help to protect your investment in the BURGMAN 400. The Suzuki Advanced Immobiliser System (SAIS)\* uses an electronic identification system in the owner's key to prevent unauthorized people from starting the engine. A magnetic cover that opens only for the owner's key protects the ignition switch for added security.

\*Not available on North American, Brazilian, or Korean specification units.



### Rear brake lock system

Located on the same side as the ignition key, the easy-to-operate brake lock lever applies a lock system that acts on the rear brake when parked. The rear brake lock system can prove useful when parking on a slope.

### Chain lock gate

The chain lock gate allows you to pass a chain lock through the bodywork, around the frame, and then around a pole or other immovable object.



### Sure footedness includes the rider's footing

Cut-away footboards make it easier to plant your feet on the ground when stopping without any of the uncomfortable stretching that comes with stop-start leg movement.

## BURGMAN SERIES

You want to look your best, whether commuting to work or enjoying a ride with a special person on your own time.

You want your ride to handle and perform well, while also reflecting your keen sense of style.

The BURGMAN 400 delivers on all fronts. It's ready to turn heads on the streets. It's equipped to carry you wherever you want to go, and to do it in style. It's the Elegant Athlete.



BURGMAN 650 Executive

BURGMAN 400 ABS

BURGMAN 200/125 ABS